



BLS Series Reverse Osmosis System

INSTALLATION, OPERATION AND MAINTENANCE MANUAL

BLS 3000 Standard Model



IMPORTANT!

Keep This Information For Future Reference.

CSBLS3000OPSTR2 07.13.11

Please read this manual carefully before attempting installation.



TABLE OF CONTENTS

Reo-Pure BLS 3000 Standard R.O. System

<u>Introduction to (R.O.) Reverse Osmosis</u>	
How Reverse Osmosis Works	1
Definition of R.O. Terms	1
Factors Effecting System Operation and Performance	1
<u>Getting to Know Your Reo-Pure R.O. System</u>	
BLS 3000 STANDARD System.....	2
<u>Reo-Pure BLS 3000 Specifications</u>	
Systems Operating Specifications	3
Minimum Feed Water Requirements	3
Space Requirements	3
Service Connections	3
Design Test Conditions	3
<u>System Installation Instructions</u>	
Unpacking Your Reo-Pure System	4
Locate a Desirable Location	4
Feed Water Supply Connection	4
Product Water Connection	4
Drain/Reject Water Connection	5
Electrical Connections	5
Connecting Tank Level Float Control	5
Install Filter Cartridge	5
<u>System Start-Up Procedure</u>	
RO Microprocessor Based System Controller	6-12
RO Microprocessor Controller Set Points	13
Divert Product Water To Drain	14
Flush The System	14
Adjust The System Pressure	14
Adjust The System Flow Rates	14
Check The Inlet Low Pressure Switch	15
<u>Reo-Pure BLS Routine Maintenance</u>	
Filter Cartridge Installation & Replacement	16
System Pressure Switches	17
Servicing the Membrane Element	18
Sanitizing the System	19
<u>Reo-Pure BLS 3000 Replacement Parts List</u>	20
<u>Reo-Pure System Limited Warranty</u>	21
<u>System Trouble Shooting</u>	22
<u>System Log Sheet</u>	23
<u>Reo-Pure BLS 3000 System Diagrams</u>	
Flow Schematic	24
Electrical Schematics	25-26

REO-PURE R.O SYSTEM INTRODUCTION

Your Reo-Pure System has been designed to produce quality water for a variety of applications. We are confident that you will find Reo-Pure Systems provide quick and simple installation, hassle-free maintenance, and years of reliable and trouble free operation.

Reo-Pure Systems incorporate years of engineering experience, dedicated workmanship, and quality manufactured components. Each system is built with pride and is factory tested for superior performance.

As with all products, the customer has the responsibility to ensure that the Reo-Pure System is operated under proper conditions and within design limitations. All installation, startup and maintenance instructions must be followed carefully.

HOW REVERSE OSMOSIS WORKS

Reverse osmosis is a separation process in which water is forced under pressure through a membrane in the opposite direction from normal. The membrane allows water to pass through, and blocks or hinders the passage of dissolved substances and suspended particles. This process reduces the dissolved salts, minerals, and suspended particles, while improving the taste, odor, and clarity of the water. The process is further enhanced by allowing the feed water to continuously pass over the surface of the membrane, sweeping away the concentrated salts, minerals and suspended particles.

The Reo-Pure membrane element divides the feed water into two streams: product water (permeate) which is now purer than before, and is the desired result; and concentrate water (reject or drain, plus recirculation) which carries the concentrated dissolved salts, minerals, and suspended particles that were rejected by the membrane element down the drain.

DEFINITIONS

Feed Water -- The incoming water to be processed by the Reo-Pure System.

Product Water -- (Permeate) -- That portion of the feed water that has passed through the membrane element. It is the desired result of a Reo-Pure System.

Concentrate Water -- (Reject or drain water, plus recirculation) Used to describe that portion of the feed water that has flowed across the membrane (not through), and has not been converted to product water. This water now contains a higher concentrate of dissolved solids and may also contain organic matter and suspended particles rejected by the membrane. The concentrate is then split into two streams, reject and recirculation. The recirculated water is mixed with the feed water on the inlet side of the pump. The reject water is sent down the drain. This design is used as a way to minimize the amount of water sent to drain.

Recovery -- The percentage of feed water which becomes product water. The recovery rate is determined by the number of gallons (or liters) of product water divided by the total gallons (or liters) of feed water, and multiplied by 100.

Percent Rejection -- The percentage of dissolved solids in the feed water that does not pass through the membrane. The membrane prevents passage of dissolved solids and other contaminants into the product water.

Conductivity -- The property of a substance to conduct or transmit electricity. The unit of measure is in mhos and is commonly used to determine the purity or quality of water. In the water treatment industry, it is often converted to PPM TDS (Parts Per Million Total Dissolved Solids).

FACTORS AFFECTING SYSTEM OPERATION AND PERFORMANCE

Feed Water Temperature -- The volume of product water increases with higher feed water temperatures, and decreases with lower feed water temperatures. Temperatures below 35^oF could crack the membrane element, and temperatures above 90^oF may cause rapid deterioration.

Feed Water Pressure -- The recommended range is between 40 PSI and 85 PSI. This is the most common range of municipal water supplies.

Hydrolysis -- The natural chemical breakdown of a membrane elements when in contact with water. This breakdown is accelerated when the water temperature is above 90^oF, the pH is not within the tolerable range, or when hydrogen sulfide is present. Refer to the SYSTEM OPERATING SPECIFICATIONS. Additional pre-treatment may be required in these cases.

Bacteria -- When R.O. Systems are operated intermittently, they will likely be exposed to bacteria. Following a shut-down or storage period, the system should be sanitized. Refer to the section in this manual regarding sanitization.

Fouling or Surface Coating of the Membrane Element -- Fouling is a common problem with membrane elements as a result of salts, hardness, iron, etc. collecting on the membrane surface. The pores and channels of the membrane element become plugged reducing the water production rate. Pre-treatment equipment, such as a water softener, iron filter, or activated carbon filter will reduce membrane element fouling and extend its life.

GETTING TO KNOW YOUR REO-OURE R.O. SYSTEM

BLS 3000 STANDARD

It is important that you familiarize yourself with the BLS 3000 RO system. Pictured below is the Reo-Pure RO system with the main components identified. These components will be referred to throughout the manual. Noting their location will assist you in start up and maintenance of the RO system.

MAJOR COMPONET PARTS LIST

- | | |
|---|-------------------------------|
| 1. S-150 R.O. MICROPROCESSOR CONTROLLER | 12. REJECT NEEDLE VALVE |
| 2. PRODUCT PRESSURE GAUGE 0-300 PSI | 13. REJECT WATER FLOW METER |
| 3. HP BOOSTER PUMP & MOTOR | 14. PRODUCT WATER FLOW METER |
| 4. PRESSURE VESSELS | 15. INLET LOW PRESSURE SWITCH |
| 5. PRESSURE REGULATOR | 16. TDS PROBE |
| 6. INLET SOLENOID VALVE | 17. PRODUCT WATER CHECK VALVE |
| 7. AUTO FLUSH SOLENOID VALVE | |
| 8. OUTLET PRESSURE GAUGE | |
| 9. 5-MICRON SEDIMENT PRE-FILTER CARTRIDGE | |
| 10. PRE-FILTER SEDIMENT HOUSING | |
| 11. INLET PRESSURE GAUGE 0-100 | |

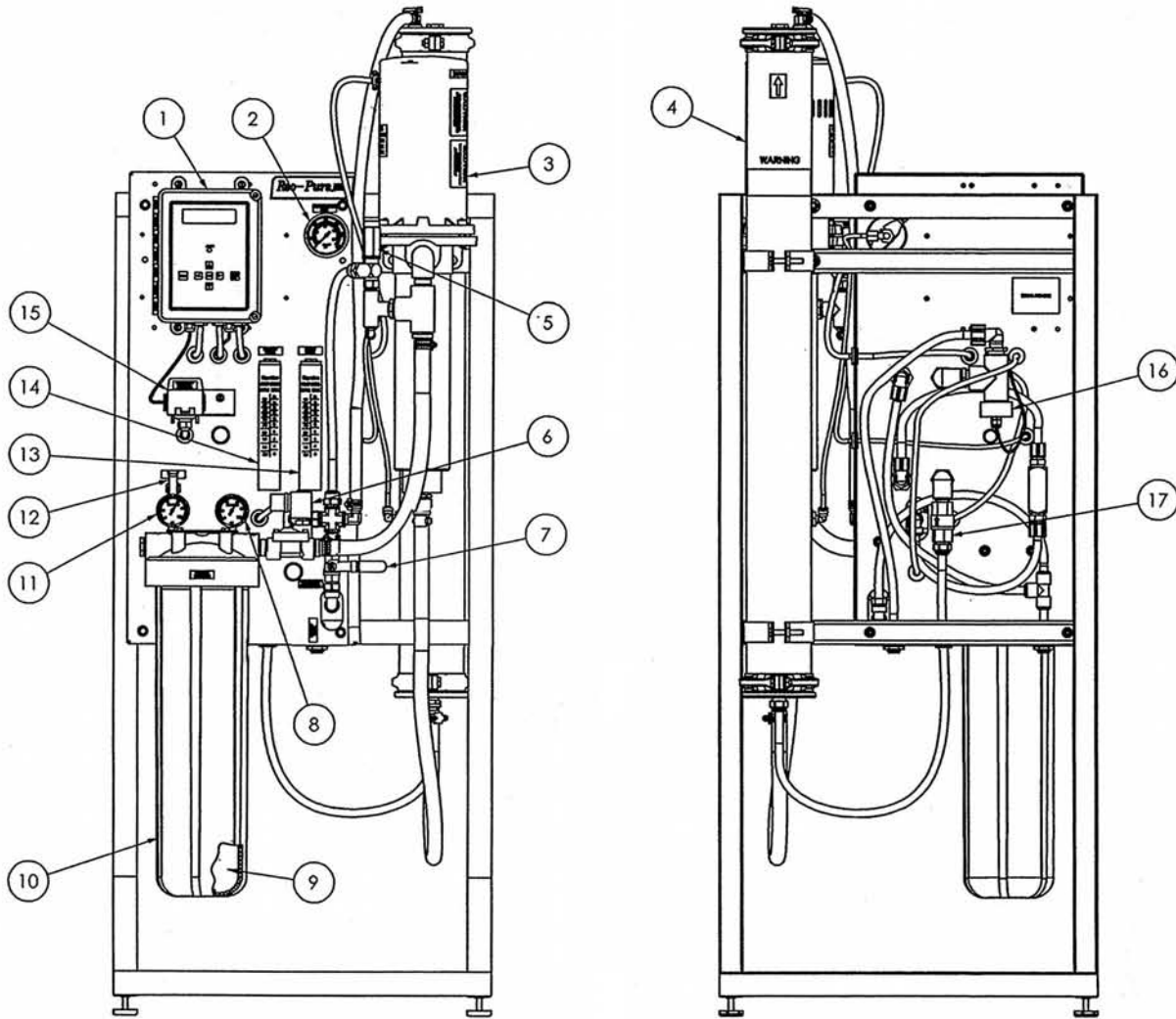

THIS MANUAL COVERS THE INSTALLATION, OPERATION AND MAINTENANCE OF MODEL BLS 3000 REO-PURE SYSTEM. IT IS IMPORTANT TO READ THIS MANUAL THOROUGHLY BEFORE INSTALLING YOU SYSTEM.

**REO-PURE BLS 3,000 and 6,000 GPD
SYSTEMS SPECIFICATIONS**

SYSTEM OPERATING SPECIFICATIONS

Model	3,000 GPD MODEL	6,000 GPD MODEL
Flow Capacity	3,000 GPD / 2.1 GPM	6,000 GPD / 4.2 GPM
Typical Recovery	70%	70%
Design Rejection	95-98%	95-98%
Number of Pressure Vessels	(1) 4 X 40 S/S	(2) 4 X 40 S/S
Number of Membrane Elements	(1) XLE-4040	(2) XLE-4040
System Operating Pressure	165 PSI	165 PSI
Nominal Flow of Feed Water During Operation	3 GPM	6 GPM
Nominal Flow of Feed Water During Fast Flush	10 GPM	13 GPM
Max. Product Water Back Pressure	50 PSI	50 PSI
*Minimum Pre-Filtration	5 Micron	5 Micron

FEED WATER REQUIREMENTS (3,000 and 6,000 GPD)

Temperature Range	40-85°F (5-30°C)
Min. Feed Water Pressure	35 PSI
Max. Feed Water Pressure	85 PSI
Chlorine Tolerance	<0.1 PPM
Maximum Hardness	10 GPG
Oil Tolerance	0.0 PPM
Max. Feed Water Silt Density Index	5
Max. Feed Water Turbidity	1 NTU
pH Range of Feed Water	3-10

SPACE REQUIREMENTS

Equipment Dimensions	3,000 GPD	6,000 GPD
	Depth: 20" Width: 24" Height: 60"	Depth: 20" Width: 24" Height: 60"
Weight (Approx.) Lbs.	200 Lbs.	250 Lbs.

SERVICE CONNECTIONS (3,000 and 6,000 GPD)

Feed Water Inlet	3/4" NPTF
Reject Outlet to Drain	1/2" TUDE OD
Product Outlet to Storage	1/2" TUBE OD

DESIGN TEST CONDITIONS (3,000 and 6,000 GPD)

Feed Water TDS	500 PPM TDS as NaCl
System Operating Pressure	165 PSI
Feed Water Temperature	77°F (25°C)
System Design Recovery	70%

****If the system is used with chlorinated water, an activated carbon filter is required.***

SYSTEM INSTALLATION INSTRUCTIONS

For BLS 3000 and 6000 Standard Models

IMPORTANT! *Installation must comply with local plumbing, electrical, and sanitation codes.*

IMPORTANT! *Do not use this system to make safe drinking water from non-potable water sources. Do not use the system on microbiologically unsafe water, or water of unknown quality without adequate disinfection before or after the system.*

Reo-Pure R.O. Systems will operate most efficiently on filtered water with a pH of less than 6.5, an SDI of 5 or less, and hardness of less than 10 GPG. If the system is operated with levels higher than these, other forms of pretreatment may be necessary.

Feed water must not contain free chlorine, formalin, quaternary germicides, cationic surfactant, detergents containing non-ionic surfactant, such as ALL or Triton, or membrane element cleaners other than those approved for use.

STEP ONE:

Unpack Your Reo-Pure BLS System

Reo-Pure Systems are carefully inspected, tested, and packaged. They are shipped in proper working order and in excellent condition.

Remove the System from the shipping container and inspect it for signs of concealed damage which may have occurred during shipping. If damage has occurred, immediately contact the delivering carrier and file a claim for damages.

STEP TWO:

Locate a Desirable Installation Site

Your Reo-Pure BLS System should be mounted on a hard, level surface capable of supporting the entire weight of the System. See the SYSTEM SPECIFICATIONS for approximate weight.

STEP THREE:

Feed Water Supply Connection

A cold water supply source must be located within close proximity to the System. This will be the inlet feed water supply. Feed water pressure must be a minimum of 35 PSI.

Remove the plug from the inlet side of the filter housing marked INLET. Connect a minimum feed water line of 3/4" hose or pipe.

CAUTION! *Do not connect a hot water line to the Reo-Pure system. Feed water must be a cold water supply!*

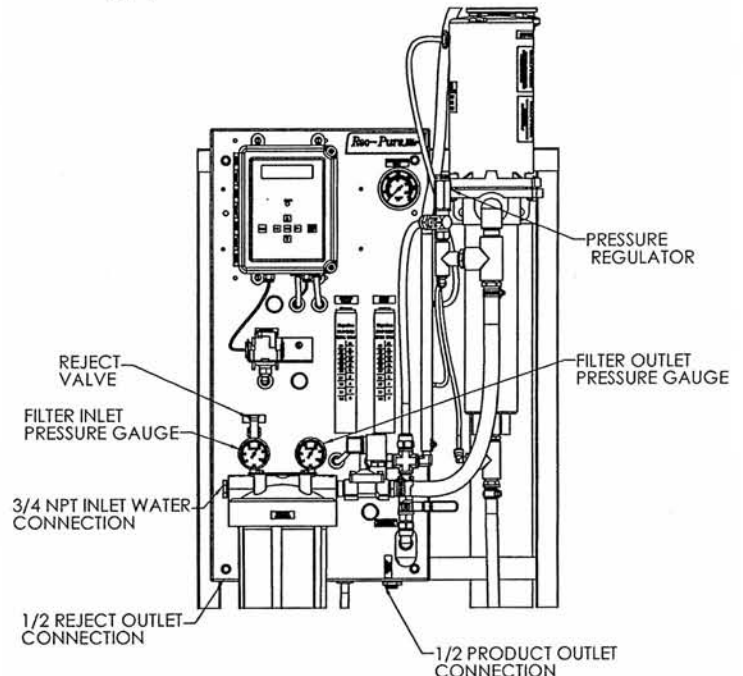

STEP FOUR:

Product Water Connection

During the initial start-up procedure, after a membrane element replacement, or after sanitization of the system, you will want to divert the product water line to your wastewater drain.

This can be done by either installing a 3-way valve in the line or by disconnecting the pipe or hose from your storage tank. It is always important to divert the product water to drain for the first 30 to 60 minutes of operation because membrane elements are treated with preservative solution that should be rinsed free.

If an atmospheric storage tank is being used, a tank level float control-switch and repressurization system (optional features) will be required to shut the system off and to pump the product water to your application.

If a pressurized storage tank is being used, the product water safety pressure switch, which is factory wired to initiate a pressure fault alarm if the product water back pressure reaches 45 PSI, must be wired directly to the TANK FULL HIGH terminals. The switch will then shut the system off when the tank pressure reaches 45 PSI. Refer to the section titled "Product Pressure Switch As System On/Off Control" in this manual.

SYSTEM INSTALLATION INSTRUCTIONS (continued)

For BLS 3000 and 6000 Standard Models

CAUTION! *Do not install a valve in the product water line unless the Product Pressure Switch / Product Pressure Relief Valve option is included with the system since serious damage can occur to the membrane elements if the system is operated with the valve closed.*

Remove the red plug from the fitting marked **PRODUCT** on the bottom of the panel toward the right side. Using 1/2" O.D. tubing, connect your product water line. Do not connect the product water line to your storage tank at this time. There will be further instructions in the System Start-Up Section regarding additional steps later. For now, divert this line to your wastewater drain.

STEP FIVE:

DRAIN / REJECT WATER CONNECTION

A waste water drain must be near the installation site. This will be your connection for the reject water (drain) which is carrying a high level of concentrated dissolved salts, minerals, and suspended particles that were rejected by the membrane element.

Remove the red plug from the fitting marked **DRAIN** on the bottom of the panel toward the left side. Using 1/2" O.D. tubing, connect it to your wastewater drain.

NOTE! *We recommend installing an air gap connection designed to prevent wastewater back flow.*

STEP SIX:

ELECTRICAL CONNECTIONS

A grounded electrical supply of the proper voltage for your System should be near the installation site. The System will be damaged if connected to a power source other than the voltage, phase and hertz specified in the final inspection report at the back of this manual. See the wiring diagram at the end of this manual for the correct power connections in the control enclosure.

CAUTION! *This system must be installed with disconnecting means required as per electrical code.*

STEP SEVEN:

Electrical Connection of Tank Level Float Control Switch & Pretreatment Interlock Switch

On terminal strip P9 on the microprocessor controller PC board, there are terminals labeled TANK FULL HIGH. A jumper was installed across these terminals before the system was shipped. Remove this jumper and connect the Normally Closed (NC) Tank Level Float Control Switch.

On terminal strip P9 on the microprocessor controller PC board, there are terminals labeled PRETREAT. A jumper was installed across these terminals before the system was shipped. Remove this jumper and connect a Normally Closed (NC) switch from the softener or filter which will open during the complete backwash/regeneration cycle.

NOTE! *If you are not using one or both of these sets of terminals, the jumpers must remain in place or the system will not operate.*

STEP EIGHT:

Install Filter Cartridge

Refer to the section titled "Filter Cartridge Installation and Replacement" in this manual.

CAUTION! *Connecting the system to a power source which does not match the system power rating exactly can damage the system and void the warranty.*

IMPORTANT! *Prior to start-up of the System, visually inspect the inlet, drain, and product water connections completed. Check to be sure the System is connected to a properly grounded electrical power supply of the appropriate voltage,*

S-150 R.O. MICROPROCESSOR CONTROLLER

CAUTION! BE SURE TO READ THE R.O. CONTROLLER SECTION CAREFULLY BEFORE ATTEMPTING TO OPERATE THIS REO-PURE SYSTEM, AND BEFORE CHANGING ANY CONTROLLER SETTINGS. DO NOT ATTEMPT TO CHANGE ANY CONTROLLER SETTINGS WITHOUT CAREFULLY READING THIS SECTION OF THE MANUAL.

CONTROLLER INTRODUCTION

Your Reo-Pure System is controlled by a Series 150 R.O. Microprocessor Controller. It is a state of the art control system for commercial and industrial R.O. systems.

The Series 150 is a microprocessor controlled system that can monitor pressure and level switches. A TDS/Conductivity monitor/controller with programmable set points is an integral part of the Series 150. The Series 150 displays system status and sensor, and switch input status on an easy to read backlit display. User programmable set points are provided that allow fast and easy adjustment of system parameters.

IMPORTANT! A table titled *FACTORY PRESET SETTINGS* is included in this manual which indicates where the set points have been factory preset. The write protect jumper J3 is in the ON position (center and right pins). To change any set point, the write protect jumper must be in the OFF position (center and left pins). After the changes are made, remember to return the jumper to the ON position and modify the preset table accordingly.

CONTROLLER SPECIFICATIONS

Power:

120/240 VAC -15+10%, 50/60Hz, 25Watts

Environment:

-22°F to 140°F, 0-95% RH, non-condensing

Display:

2 line X 20 character, alphanumeric backlit LCD

Front Panel:

Overlay with LCD window, alarm lamp,
7 key membrane switch

Switch Inputs, Dry Contact:

Pressure fault
Pretreat lockout
Tank full high
Tank full low

Relay Outputs:

RO pump relay	120/240VAC, 1HP
Inlet valve relay	120/240VAC, 5A
Flush valve relay	120/240VAC, 5A
Relays	supply same output voltage as board power (120 or 240 VAC)

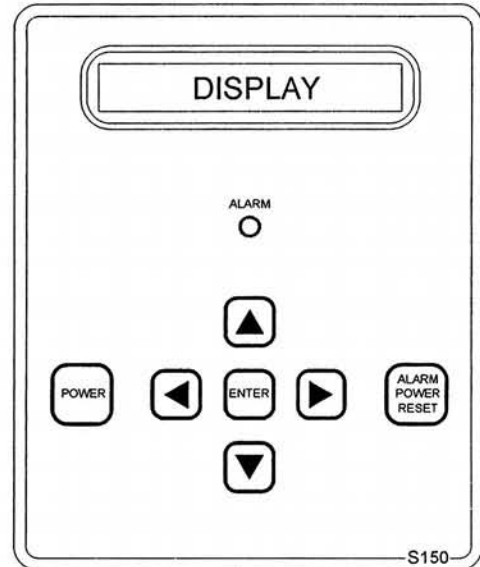

Figure 1

Cell:

TDS/C

Conductivity cell with digital display, standard range, 0-250PPM or uS. Other ranges available: 50, 100, 500, 1000, 2500, 5000. Wetted parts ABS and 316 S.S., 3/4" NPTM, 300 PSI max.

Optional I/O Expander:

Auxiliary/divert/boost relay	120/240VAC, 1 HP
Divert/alarm relay	120/240VAC, 5A
Low tank switch input	Dry Contact

FRONT PANEL CONTROLS AND INDICATORS

DISPLAY - Shows status of system.

ALARM LAMP - Flashes when fault causes an RO shut down. On steady when a set point is exceeded that does not cause an RO system shut down.

POWER KEY - Places controller in operating or standby mode.

LEFT ARROW KEY - Scrolls through set points starting with first set point.

RIGHT ARROW KEY - Scrolls through set points starting with last set point.

UP ARROW KEY - Increases value of set point.

DOWN ARROW KEY - Decreases value of set point.

ENTER KEY - Confirms entry of new set point.

ALARM SILENCE/RESET KEY - Push once for alarm silence and twice to reset system after a shut down has occurred.

S-150 R.O. MICROPROCESSOR CONTROLLER CONTINUED

TERMINAL STRIP, JUMPER AND ADJUSTMENT LOCATIONS

Refer to the Electrical Schematic for the location of all terminal strips and connectors. The Electrical Schematic also shows all jumper and adjustment locations.

POWER WIRING

Refer to the Electrical Schematic for terminal strip and jumper locations. Before applying power to the unit, verify that the voltage jumpers are configured correctly for the voltage that will power the unit. The voltage jumpers are located below the transformer. For 120VAC operation, there should be a wire jumper installed between P2 and P3 and a second wire jumper installed between P4 and P5. For 240VAC operation, a single wire jumper should be installed between P3 and P4.

AC power for the unit is connected to terminal strip P1. Connect the ground wire of the AC power to the terminal labeled GND. For AC power with a neutral and hot wire, the hot wire connects to L 1 and the neutral wire connects to L2. For AC power with 2 hot wires, either wire can connect to L 1 and L2. On AC power with 2 hot wires, the wire jumper between P6 and P7 should be removed and a fuse (GMA 1/4A) installed in F2.

PUMP AND VALVE RELAY OUTPUTS

The Series 150 supplies relay outputs to control the RO pump and solenoid valves. NOTE: The relays output the same voltage as the AC power to the board. If the pump and solenoids operate on different voltages, a contactor will need to be supplied to operate the pump.

RO PUMP WIRING

The RO pump connects to the L1 and L2 RO pump terminals of P1. This output can operate 120/240VAC motors up to 1 HP directly. For motors larger than 1 HP or 3 phase motors, this output can be used to operate a contactor.

INLET AND FLUSH VALVE WIRING

The inlet and optional flush valves must operate at the same voltage as supplied to the board. These outputs can supply 5A maximum and are not designed to operate pump motors directly. If these outputs are to be used to operate a boost or flush pump, the output should be used to operate a contactor. The inlet valve connects to the L1 and L2 inlet terminals of P1. The optional flush valve connects to the L1 and L2 flush terminals of P1.

TDS/CONDUCTIVITY CELL WIRING

For accurate TDS/Conductivity readings, the cell should be installed in a tee fitting where a continuous flow of water passes over the cell and no air can be trapped around the cell. The cell is connected with 5 wires to terminal strip P10. Connect each colored wire to the terminal labeled with the same color.

SWITCH INPUTS

Switch inputs are connected to P9. The connections for these inputs are not polarity sensitive and can be connected to either terminal. The switch inputs should be dry contact closures only.

IMPORTANT! Applying voltage to these terminals will damage the Controller. The switches can be either normally open or normally closed in any combination. The switch connected to an input that is configured as normally open must be open for the unit to run. The switch connected to an input that is configured as normally closed must be closed for the unit to run. The Switch Select Set Point allows each input to be configured as normally open or normally closed. The Switch Select Set Point is defaulted to 0 which programs all inputs as normally open. Table 1 lists the values used to program the Set Point to configure the inputs.

SWITCH	N.O.	N.C.	VALUE
PRESSURE FAULT	0	1	1
PRETREAT	0	2	2
TANK FULL HIGH	0	4	4
TANK FULL LOW	0	8	0
TANK LOW	0	16	0
		TOTAL	7

TABLE 1

Select the type of switch used for each input and put that number in the value column. Add the values and program the total in the Switch Select Set Point. For example, if the pressure fault and tank low inputs were normally closed and all others normally open, the value programmed in the Switch Select Setpoint would be 17 (1 + 16).

PRESSURE FAULT SWITCH

On systems where a low feed pressure shut down is required, a feed pressure switch can be connected to the pressure fault input of P9. If a high pump pressure shut down is required, a high pressure switch can be connected to this input. If both low feed pressure and high pump pressure shut down are required, both switches can be connected to this input. Both switches must be either normally open or normally closed to operate properly.

PRETREAT SWITCH

In systems with pretreatment, a pretreat lockout switch can be connected to the pretreat input of P9. This switch should operate when the pretreatment device is out of service. Remove the red jumper when this option is used. Refer to the Electrical Schematic for terminal strip and jumper locations.

S-150 R.O. MICROPROCESSOR CONTROLLER CONTINUED

IMPORTANT! *The output from the pretreatment device must be a dry contact and must not supply voltage.*

TANK FULL SWITCH

In systems with a single tank level switch for controlling the RO pump, the level switch connects to the tank full high input of P9. If dual level switches are used for controlling the RO pump, the upper level switch connects to the tank full high input of P9 and the lower level switch connects to the tank full low input of P9. Remove the red jumper when this option is used. Refer to the Electrical Schematic for terminal strip and jumper locations.

IMPORTANT! *The output from the tank level switch must be a dry contact and must not supply voltage.*

I/O EXPANDER BOARD

If the optional I/O expander board is installed, 2 additional relay outputs and 1 additional switch input are provided. Refer to the Electrical Schematic for the location of terminal strips, jumpers and wiring for this board. AC power for the relays is connected to the L 1 and L2 power terminals of P1. Relay 1 is connected to this power input and will supply the same voltage. This relay is rated for 120/240VAC at 1HP maximum. Relay 1 can be configured to supply a dry contact by connecting a jumper wire between the L 1 and L2 power terminals of P1.

NOTE! *If Relay 1 is configured as a dry contact, Relay 2 must be configured as a dry contact also. If Relay 1 is configured to supply voltage, Relay 2 can be selected to supply voltage, 120/240, 5A maximum, or as a dry contact output.*

Jumpers J1-J4 are used to select the relay 2 output type. To output voltage, a wire jumper is installed between J1 and J4 and a second wire jumper is installed between J2 and J3. For a contact closure output, a single wire jumper is installed between J3 and J4. The 2 relay outputs can be selected to operate as an auxiliary pump output, a divert output or an alarm output by programming the Expander Mode Set Point. Table 2 shows the values used to program the relay outputs.

EXPANDER MODE	RELAY1	RELAY 2
0	AUXILIARY PUMP	DIVERT
1	AUXILIARY PUMP	ALARM
2	DIVERT	ALARM
3	BOOST	DIVERT
4	BOOST	ALARM

TABLE 2

AUXILIARY PUMP

If the Expander Mode Set Point is programmed to 0 or 1, relay 1 operates as an auxiliary pump output. This output is energized when the tank low input is not active. This output will supply power or a contact closure determined by the connections L1 and L2 of the terminal strip P1.

BOOST PUMP

If the Expander Mode Set Point is programmed to 3 or 4, relay 1 operates as a boost pump output. This output is energized when the inlet solenoid output is active. This output will supply power or a contact closure determined by the connections L1 and L2 of the terminal strip P1.

DIVERT OUTPUT

If the Expander Mode Setpoint is programmed to 0 or 3, relay 2 operates as a divert relay and will operate whenever the unit is in the divert mode. This output will supply voltage or provide a contact closure based on the configuration of relay 1 and on the position of jumpers J1-J4. If the Expander Mode Setpoint is programmed to 2, relay 1 operates as a divert relay and will operate whenever the unit is in the divert mode. This output will supply power or a contact closure determined by the connections L1 and L2 of the terminal strip P1.

ALARM OUTPUT

If the Expander Mode set point is programmed to 1, 2 or 4, relay 2 operates as an alarm relay. When an alarm or warning is active, this relay will supply voltage or provide a contact closure based on the configuration of relay 1 and the position of jumpers J1 - J4.

TANK LOW SWITCH

A tank low switch input can be connected to the tank low input of P2 on the expander board. This input will provide a tank low warning on the unit and if the expander is programmed to provide an auxiliary pump or boost pump output, will provide low tank level protection for the pump.

TO DISPLAY OR CHANGE SETPOINTS

1) Refer to Figure 1 for the location of the keys used to display or change the set points and the Electrical Schematic for the location of the write protect jumper, J3. For the unit to be able to accept a change in a set point, the shorting jumper must be in the off position(center and left pins).

NOTE: *Set points cannot be changed if the write protect jumper is in the ON position.*

2) Use the Left and Right arrow keys to display the set points. Each press of an arrow key will advance the display to the next set point. The Left arrow key starts with the beginning set point and the Right arrow key starts with the last set point.

S-150 R.O. MICROPROCESSOR CONTROLLER CONTINUED

- 3) The Up and Down arrow keys are used to increment or decrement the set point value. The value will change by 1 count each time a key is pressed. If the key is pressed and held for ~ 1 second, the set point value will change at a fast rate. When the key is released, the fast rate will be reset. Pressing both the Up and Down arrow keys together will reset the set point value to 0.
- 4) Pressing the Alarm Silence/Reset key at any time will cancel the operation and return the display to the main screen.
- 5) To accept the new set point value, press the Enter key.
- 6) The unit will beep twice if the change is accepted. If the write protect jumper is on, the unit will show WRITE PROTECTED on the display and one long beep will sound.
- 7) When finished changing Setpoints, the write protect jumper should be placed in the on position(center and right pins).

SYSTEM OPERATION

The unit has 2 modes of operation, a standby mode and an operating mode. In the standby mode, the unit is effectively off. All outputs are turned off and the display shows STANDBY. In the operating mode, the unit operates automatically. All inputs are monitored and the outputs are controlled accordingly. Pressing the Power key will toggle the unit from standby to operate or from operate to standby. If power is removed from the unit, when power is reapplied, the unit will restart in the mode it was in when power was removed.

DISPLAY

The display is a 2 line x 20 character backlit liquid crystal display. System operating status and sensor readings are shown on this display. Setpoint information is also shown on this display.

OPERATING STATUS MESSAGES

The operating status of the unit is shown on the top line of the display. The following list describes the items shown for the operating status.

STANDBY - The unit is in the standby mode.

DELAY 99 - The unit is in the RO start delay. The number is the seconds remaining before the RO pump starts.

OPERATING - The RO unit is operating.

TANK FULL - The unit is shut down due to a tank full condition.

TANK FULL 99 - The unit is shut down due to a tank full condition. If the number is blinking, the tank full high switch has cleared, but the tank full low switch is still active. If the number is on steady, both tank level switches have cleared and the delay is counting down.

PRETREAT - The unit is shut down due to a pretreat lockout condition.

PRESS FAULT - The unit is shut down due to a pressure fault condition.

MEMB FLUSH 99 - Membrane flush is active. The number is the minutes remaining in the flush cycle.

TDS/CONDUCTIVITY

The TDS/Conductivity is shown on the top line after the unit operating status. When the unit is offline because of a shut down condition, the reading is replaced with '- - -'. If the reading is over range, the reading is shown as '^ ^ ^ ^'.

OPERATING HOURS

The current operating hours are shown on the bottom line.

TEMPERATURE

The current water temperature is shown on the bottom line after the operating hours. When the unit is offline because of a shut down condition, the reading is replaced with '- - -'.

WARNING MESSAGES

Warning messages are also shown on the second line. If any warnings are active, the active warnings will alternate with the normal displays for the bottom line. The following lists the warning messages.

HI TDS/COND - The TDS/Conductivity reading has exceeded the programmed limit.

TANK LOW - The tank low input is active.

TANK LOW 99 - The tank low input has cleared, but the tank low restart delay is active. The number is the minutes left in the delay.

OP HOURS EXCEEDED - The current operating hours have exceeded the programmed limit.

S-150 R.O. MICROPROCESSOR CONTROLLER CONTINUED

TANK FULL OPERATION

The unit can be operated with 1 or 2 level switches. With level switch, the switch is connected to the tank full high input. When this switch has been active for 5 seconds, the unit will shut down on tank full. TANK FULL will show on the display. When the tank full condition clears, the display will show TANK FULL 99. The number is the tank full restart time and the unit will restart when this delay times out.

For 2 level switch operation, the upper switch is connected to the tank full high input and the lower switch is connected to the tank full low input. When both switches are clear, the unit will run. The RO unit will continue to run when the water level rises and the lower switch becomes active. When the upper switch becomes active, after the 5 second delay, the unit will shut down.

TANK FULL will show on the display. When the tank level drops and the upper level switch clears, the display will show TANK FULL 99 and the RO unit will remain off. The number is the tank full restart time and the number will blink until the lower level switch clears. When the lower level switch clears, the number will remain steady and it will restart when the delay times out.

TANK FULL RESTART

The tank full restart is the delay before the RO unit starts when a tank full condition clears. This delay can be in minutes or in seconds. The TF Restart Set Point selects seconds or minutes.

TANK FULL OVERRIDE

A timed tank full override can be initiated when the RO unit is shut down due to a tank full condition. Pressing the Alarm Silence/Reset key for 3 seconds during a tank full condition will enable the tank full override. The RO will start and TF OVERRIDE 9 will show on the display. The number is the minutes remaining in the override timer. When the override times out, the unit will return to the tank full shut down condition.

PRESSURE FAULT

If the pressure fault input becomes active and stays active for the delay programmed in the PF Delay Setpoint, the unit will shut down for a pressure fault. The display will show PRESS FAULT, the alarm lamp will flash and the audible alarm will sound. The pressure fault can be cleared by pressing the Alarm Silence/Reset key twice.

AUTO RESET

If a pressure fault shut down occurs and the Auto Reset Setpoint is programmed to 0, the unit will remain shut down until manually reset. If the Auto Reset Setpoint is programmed to a value greater than 0, the unit will automatically clear the pressure fault and attempt to restart after this delay times out.

ALARM SILENCE

When a shut down occurs that causes the audible alarm to sound, the alarm can be silenced by pressing the Alarm Silence/Reset key once. The alarm will remain silenced if the Alarm Silence Setpoint is programmed to 0. If the Alarm Silence Setpoint is programmed to a value greater than 0, the alarm will resound after this delay times out. Pressing the Alarm Silence/Reset key will silence the alarm and rest the delay.

PRETREAT

If the pretreat input becomes active and stays active for 2 seconds, the unit will shut down in a pretreat lockout condition. PRETREAT will show on the display and the unit will remain shut down as long as the pretreat input is active.

OPTIONAL MEMBRANE FLUSH MODE

If the RO system was ordered with the AUTO FLUSH OPTION, the Flush Mode Set Point can be used to control the operation of the inlet valve and RO pump during flush. Each can be independently programmed to operate during flush. Table 3 shows the values to program into the Flush Mode Set Point to control the operation of the inlet and RO outputs during flush.

FLUSH MODE	RO PUMP	INLET VALVE
0	OFF	CLOSED
1	OFF	OPEN
2	ON	CLOSED
3	ON	OPEN

TABLE 3

OPTIONAL MEMBRANE AUTO-FLUSH

If the Flush Type Set Point is programmed to 0, flush is disabled. If membrane flush is desired, several types of flush are available. When the unit enters a flush cycle, the flush relay will activate. The flush cycle will last for the time programmed in the Flush Time Setpoint. Table 4 shows the value that must be programmed in the Flush Type Setpoint for each type of flush.

TANK FULL - The RO unit will flush each time a tank full condition occurs.

OPERATING HOURS - A flush will occur when the RO pump has operated for the number of hours programmed in the Flush Interval Setpoint.

ELAPSED TIME - A flush will occur after the number of hours programmed in the Flush Interval Setpoint has passed.

S-150 R.O. MICROPROCESSOR CONTROLLER CONTINUED

FLUSH TYPE	DESCRIPTION
0	NO FLUSH
1	TANK FULL
2	OPERATING HOURS
3	OPERATING HOURS AND TANK FULL
4	ELAPSED TIME
5	ELAPSED TIME AND TANK FULL
6	OFF HOURS
7	OFF HOURS AND TANK FULL
8	RO START/STOP

TABLE 4

OFF HOURS - A flush will occur when the RO has been shut down due to a tank full condition for the number of hours programmed in the Flush Interval Set Point.

RO START/STOP - A flush will occur each time the RO starts or stops.

The tank full flush can be combined with any of the 3 interval flush types. A manual flush can be initiated by pressing the Alarm Silence/Reset key for 3 seconds.

HIGH TDS/CONDUCTIVITY WARNING/ALARM

If the TDS/Conductivity reading exceeds the limit programmed in the TDS/Cond Delay Setpoint, the alarm lamp will light and the HI TDS/COND warning message will show on the display. This warning will clear when the TDS/Conductivity drops below the set point. If the TDS/Cond Shutdown set point is programmed to 0, the unit will continue to operate. Otherwise, once a high TDS/ICOND warning occurs, after the time programmed in this set point, the RO unit will shut down and the alarm will sound. The alarm can be cleared by pressing the Alarm Silence/Reset key twice.

OPERATING HOURS EXCEEDED

If the current hours exceed the limit programmed in the Maximum Hours Setpoint, the alarm lamp will light and the OP HOURS EXCEEDED warning message will be shown. This warning can be cleared by programming the current hours to 0 or by increasing the maximum hours limit.

I/O EXPANDER

The I/O Expander board adds 2 relays and 1 switch input. The operation and programming of the 2 relays is described in the installation section.

AUXILIARY OUTPUT

Relay 1 can be used to control a repressurization pump when relay 1 of the expander board is configured operate

an aux relay. In this mode, this relay will be energized as long as the tank low input is not active. When energized, the relay supplies power to the repressurization pump.

TANK LOW

The tank low input function has two modes of operation based on the setting of the expander mode setpoint. For auxiliary pump operation, when the tank low input has been active for 5 seconds, the auxiliary output will turn off. The alarm lamp will light and the TANK LOW warning message will show on the display. When the tank low condition clears, the TANK LOW 99 warning message is displayed. The number is the delay in minutes before the auxiliary relay will energize.

For boost pump operation, when the tank low input has been active for 5 seconds, the boost pump output will turn off, the RO unit will shutdown, the alarm lamp will flash and the audible alarm will sound. TANK LOW shutdown message will show on the display. When the tank low condition clears, the TANK LOW 99 shutdown message is displayed. The number is the delay before the RO unit will restart. The shutdown can be manually reset by pressing the Alarm Silence/Reset button twice.

BOOST PUMP OUTPUT

Relay 1 can be used to control a boost pump when the expander board is configured to operate relay 1 as a boost pump relay. This relay will operate the same as the inlet solenoid relay. This option is used to directly operate a boost pump up to 1 HP.

DIVERT OUTPUT

When relay 1 or relay 2 has been programmed to operate as a divert relay, the relay will energize when the TDS/Conductivity exceeds the TDS/Cond Limit Setpoint. This will occur as soon as the reading exceeds the limit, there is no delay. When the reading drops below the limit and stays below the limit continuously for 5 seconds, the divert relay will turn off.

ALARM OUTPUT

When relay 2 has been programmed to operate as an alarm relay, the relay will energize whenever a warning or alarm condition occurs. The relay will remain energized as long as the warning/alarm condition is active.

CONTROLLER ADJUSTMENTS

TDS/CONDUCTIVITY CALIBRATION

Refer to the Electrical Schematic for adjustment location. To calibrate the TDS/Conductivity, place the cell in a known standard solution. Adjust the span adjustment for the correct reading. If the cell is installed, the unit can be calibrated by taking a sample of the permeate water and testing it with a known, good meter.

S-150 R.O. MICROPROCESSOR CONTROLLER CONTINUED

Adjust the span control until the reading matches the meter.

NOTE: *If the TDS/Cond range is changed, the unit must be recalibrated AND some components may need to be changed.*

DISPLAY ADJUSTMENTS

The display contrast can be adjusted for best viewing by adjusting control R3. This control is located toward the upper right corner of the board, just to the left of the cell connector.

CONTROLLER TROUBLESHOOTING

CAUTION! HAZARDOUS VOLTAGES ARE PRESENT WHEN POWER IS APPLIED TO THE UNIT. CARE SHOULD BE TAKEN WHEN TROUBLESHOOTING ANY OF THE INPUT POWER OR OUTPUT CIRCUITS. WHEN DISCONNECTING OR CONNECTING ANY BOARD OR ACCESSORY, BE SURE POWER IS TURNED OFF AT THE DISCONNECT.

Before contacting your Reo-Pure Dealer for technical help, verify the programming of all set points, check the display, and check the status of all lights and indicators. The more information available when you contact us, the easier it will be to determine the source of the problem.

SYSTEM INOPERATIVE

Is the yellow CPU active LED blinking? If no, is the green power LED, DS1 lit? If no, is the fuse OK? If no, replace the fuse. If yes, with a voltmeter, verify power is applied to the power terminals L1 and L2. If power is applied to the power terminals and the above checks are OK, the board is probably defective and should be replaced. If no power is applied to the board, check the power wiring to the system.

DISPLAY BLANK

Is the green power LED, DS1 lit? If no, refer to the system inoperative section. If yes, is the CPU active LED, DS9 blinking? If no, replace the board. If yes, adjust the display contrast adjustment, R3. Is the display still blank? If yes, replace the board.

INLET VALVE WILL NOT OPERATE

Is the system in standby? If no, are any shut down conditions active? If no, is the inlet LED, DS8 lit? If no, replace the board. If yes, with a voltmeter, verify if there is power on the inlet terminals. Is there power? If no, replace the board. If yes, check the valve and wiring.

RO PUMP WILL NOT OPERATE

Is the system in standby? If no, are any shut down conditions active? If no, is the RO LED, DS6 lit? If no, replace the board. If yes, with a voltmeter, verify if there is power on the RO pump terminals. Is there power? If no, replace the board. If yes, check the pump and wiring.

UNIT NOT FLUSHING OR NOT FLUSHING CORRECTLY

Verify that flush **NOTE:** *If the TDS/Cond range is changed, the unit must be recalibrated AND some components may need to be changed.*

is enabled and what type of flush is selected. Is flush enabled? If no, enable flush. If yes, press the Alarm Silence / Reset key for 3 seconds. Does the unit show flush on the display? If no, replace the board. If yes, is the flush LED, DS10 lit? If no, replace the board. If yes, with a voltmeter, verify if there is power on the flush terminals. Is there power? If no, replace the board. If yes, check the valve and wiring.

NO OR INCORRECT TDS/CONDUCTIVITY READING

Is sensor wired correctly? If no, correct wiring. If yes, is sensor installed as described in the installation section? If no, install correctly. If yes, verify correct TDS/Conductivity range. Range correct? If no, correct range. If yes, calibrate unit. Does unit calibrate OK? If no, disconnect green and white wires of sensor. Does reading show 0? If no, replace board. If yes, reconnect wires and remove sensor from piping and dry. Does reading show 0? If no, replace cell. If yes, short pins of cell together. Does reading show 'Λ Λ Λ Λ'? If no, replace board.

REO-PURE R.O. CONTROLLER SET POINTS

S-150 MICROPROCESSOR CONTROLLER

SET POINT	DESCRIPTION	RANGE	DEFAULT VALUE	PRESET VALUE
TDS/COND. LIMIT	When this value is met or exceeded, the alarm lamp will light and high TDS/Cond will show on the display. TO disable, set to 0.	0-999 Us or PPM	100	100
TDS/COND. DELAY	When the limit Setpoint is exceeded, no alarm will be given until this time has expired.	0-999 seconds	30S	30S
TDS/COND. SHTDWN	Once a TDS/Cond alarm is active, if the time is exceeded, a TDS/Cond shut down will occur. To disable, set to 0.	0-99 minutes	0M	0M
PRESS FAULT DELAY	The amount of time between the inlet valve opening and the RO pump start.	0-99 seconds	60S	60S
R.O. START DELAY	The time a pressure fault must be active before a pressure fault shut down occurs.	0-99 seconds	5S	5S
AUTO RESET	When a pressure fault shut down is active, the system will attempt to restart after this delay. If set to 0, system must be manually reset.	0-99 minutes	60M	60M
ALARM SILENCE	If the audible alarm is silenced, after this delay, the alarm will resound. If set to 0, the alarm will remain silenced.	0-99 minutes	0M	0M
TF RESTART DELAY	When a tank full condition clears, the system will restart after this delay.	0-99 sec./min.	2S	2S
TF RESTART	Selects whether the tank full restart delay is in seconds or minutes. 0 = seconds, 1 = minutes.	0-1	0	0
TFO TIME	The amount of time a tank full override lasts.	0-9 minutes	5M	5M
TANK LOW RESTART	When a tank low condition clears, the auxillary or boost pump will restart after this delay.	0-99 minutes	15M	15M
FLUSH TYPE	Selects the type of flush. Set to 0 to diable flush.	0-8	8	8
FLUSH TIME	The length of time a membrane flush cycle will last when flush is active.	0-99 minutes	1M	1M
FLUSH INTERVAL	The interval between flush cycles. Only valid with op hour, elapsed time or off flush types.	0-99 hours	24	24
FLUSH MODE	Selects if the inlet and RO pump relays operate during flush.	0-3	0	3
MAXIMUM HOURS	If the current operating hours exceed this limit, the operating hours warning will occur. To disable, set to 0.	0-65000 hours	0	0
CURRENT HOURS	Current number of hours of RO system operation.	0-65000	0	0
EXPANDER MODE	Selects how the relays on the I/O expander board operate.	0-4	0	0
TEMP. OFFSET	Allows adjustment of temperature reading by +/- 5 degrees.	<5° / +5°	0°	0°
TEMP. UOM	Selects display of temperature in °F or °C.	0-1	0	0
SWITCH SELECT	Selects if switch inputs are normally open or normally closed.	0-32	0	7
TDS/COND. UOM	Selects display of water quality in Us or PPM. NOTE: If this setpoint is changed the unit must be recalibrated.	0-1	0	1
TDS/COND. RANGE	Selects range of TDS/Conductivity monitor. 0 = 50, 1 = 100, 2 = 250, 3 = 500, 4 = 1000, 5 = 2500, 6 = 5000	0-6	2	1

SYSTEM START-UP PROCEDURE

For BLS 3000 & 6000 Standard Systems

STEP ONE:

Installation Follow-Up

- 1) Visually inspect the inlet, drain, and product water connections.
- 2) Be sure the filter cartridge has been installed.
- 3) Confirm the Reo-Pure System has been connected to the proper power source.

STEP TWO:

Read The Section On The R.O. Microprocessor Controller

It is important to read the R.O. Controller Section carefully before attempting to operate this Reo-Pure System, and before changing any Controller settings.

STEP THREE:

Divert Product Water To The Drain

Upon initial System start-up, or after changing membrane elements, it is important to divert the product water to drain for approximately 30-60 minutes. This is done because membrane elements are treated with a preservative solution and should be thoroughly rinsed clean of any remnant. Once the preservative is flushed from the System, product water can be retained for use. This can be done either by installing a 3-way valve in the product water line, or by disconnecting the tube from your application.

STEP FOUR:

Manually Flush The System

4. Turn on the inlet feed water supply source, allowing water to enter the System.
5. Manually adjust the reject water control valve to the fully open position.
6. Open the Manual Flush valve.
7. Press the POWER key on the R.O. Controller front panel. The inlet solenoid valve will open, and the pump will start after a 60 second delay. The air will quickly evacuate from the System.

The solenoid valve is a safety device that is used to prevent water flow through the System when it is not in operation. Low inlet feed water flow and low pressure can result in damage to the pump, motor, and/or membrane element. When the System is turned on, the solenoid valve automatically opens. The valve will close when the System is turned off. The System will only start if there is sufficient feed water flow and pressure (minimum 35 PSI).

The Reo-Pure System's start delay settings are easily adjusted. The settings are covered in the R.O. Controller Section.

8. Allow the System to run approximately 15-30 minutes to bleed all trapped air and to flush the membrane element.
9. Close the Manual Flush valve.

STEP FIVE:

Adjust The System Pressure

10. Adjust the pressure regulator so that the System pressure gauge reads 165 PSI. Turn the valve counterclockwise to decrease the pressure and clockwise to increase the pressure.

CAUTION! NEVER ALLOW THE REO-PURE SYSTEM PRESSURE TO EXCEED 185 PSI.

NOTE! The gallons per day of product water produced will vary at each installation based on the feed water TDS, feed water temperature and the back pressure on the System. The purpose of recording the data on the System Log Sheet at start-up is to have a reference point to evaluate System performance during the life of the membrane element(s).

STEP SIX:

Adjust The System Flow Rates

11. This Reo-Pure System was designed to operate at 70% recovery. This may vary depending on your feed water condition and/or application. Adjust the reject water control valve, while monitoring the reject water and the product water flow meters. Refer to the GPM flow rates listed below as a guideline. *NOTE: These flow rates should only be used as a guideline! They have been determined based on the BLS 3000/6000 Standard Test Conditions. Actual flow rates should be determined based on your specific site conditions.

*BLS 3000 Model	0.9 GPM Reject Water 2.1 GPM Product Water
-----------------	---

*BLS 6000 Model	1.8 GPM Reject Water 4.2 GPM Product Water
-----------------	---

You will need to readjust both the system Pressure Regulator and the Reject Water control valve to reach your desired flow rates and the Pump/System Pressure.

Product and reject water flow rates can be read directly from the flow meters and will become a reference point for future system performance evaluation.

IMPORTANT! Frequently check the System for any leaks that may develop.

SYSTEM START-UP PROCEDURE (CONTINUED)

For BLS 3000 & 6000 Standard Systems

STEP SEVEN:

Check The Inlet Low Pressure Switch

You will find an inlet feed water low pressure switch installed on this Reo-Pure System. It is preset at the factory. Its purpose is to prevent damage to the System pump and/or motor if there is inadequate feed water flow or pressure. This step is to verify that it is functioning properly.

Slowly decrease the inlet feed water supply by closing the manual feed water shut-off valve, while watching the post filter pressure gauge. If you hear the pressure switch open when the pressure drops to approximately 15 PSI, then the inlet pressure switch is functioning correctly. If it is not functioning correctly, refer to the Section of this manual on System Pressure Switches.

NOTE! *When humidity is high, expect condensation to form on parts of the System which contain cold water.*

STEP EIGHT:

Purge the System

After approximately one hour of operation, reconnect the product water line to your application. If a storage tank is being used, it may take several hours for it to fill with product water.

STEP NINE:

Final Inspection of Installation

Once the above procedures are completed, visually inspect all water connections. Check to be certain that all connections are tight and secure.

CAUTION! *A WATER SOFTENER SHOULD NOT BE ALLOWED TO REGENERATE WHILE THE REO-PURE SYSTEM IS OPERATING UNLESS SAFEGUARDS ARE USED TO BE SURE THE SYSTEM IS SHUT-DOWN OR OPERATING ON A ALTERNATE SOURCE OF SOFTENED WATER. TERMINALS FOR SHUTTING DOWN THE SYSTEM DURING SOFTENER REGENERATION ARE PROVIDED. A NORMALLY CLOSED CONTACT FROM THE SOFTENER CONTROLLER CAN BE WIRED TO THE PRETREAT TERMINALS IN THE R.O. CONTROLLER. BYPASSING THE WATER SOFTENER AND FEEDING HARD WATER DIRECTLY TO THE REO-PURE SYSTEM WILL CAUSE PREMATURE FOULING OF THE MEMBRANE ELEMENT(S).*

FILTER CARTRIDGE INSTALLATION & REPLACEMENT

For BLS 3,000 to 18,000 Models

FILTER CARTRIDGE INSTALLATION

NOTE! The sediment filter cartridge for your Reo-Pure System has been packaged separately and will need to be installed prior to start-up.

- 1) Remove the filter cartridge from the packaging.
- 2) Unscrew the filter housing sump.
- 3) Insert the cartridge over the standpipe in bottom of the sump.
- 4) Replace the sump by turning counter-clockwise and hand tighten. **DO NOT OVER TIGHTEN.**

NOTE! The membrane element(s) have been installed in the system during the final testing procedures, unless other arrangements have been made with the manufacturer.

CAUTION! It is important that the O-ring be properly seated each time the filter housing is reassembled or removed. Use only food grade silicone or glycerin to lubricate the O-rings. Do not use a petroleum based product such as Vaseline.

CHANGING FILTER CARTRIDGES

Filter cartridges have a limited service life and should be replaced if you experience noticeable changes in product water taste, color, odor, or flow rate. On average, filter cartridges should be replaced about every 3-6 months.

Your Reo-Pure System is equipped with a pre- and post-filter gauge. An increase in the pressure difference of 10-12 PSI between the two gauges, is an indication that the filter cartridge may need to be replaced.

- 1) Close the manual feed water shut-off valve.
- 2) The System will shut down after 5 seconds and the Pressure Fault alarm will light/sound.
- 3) Disconnect the main power supply.

IMPORTANT! Before performing any maintenance on your Reo-Pure System, always disconnect the power supply!

- 4) Relieve pressure from the System by adjusting the reject water flow control valve to its open position. Remove the sump by turning clockwise. Locate and remove the large O-ring, then wipe it clean of lubricant and set it aside. It is common for the O-ring to lift out of the sump and stick to the cap. If the O-ring appears to be damaged or crimped, it should be replaced.
- 5) Remove and discard the used filter cartridge.
- 6) Rinse out the bottom of the sump and fill about 1/3 full of water. Add about two tablespoons of bleach and scrub the cap and housing with a nonabrasive sponge or cloth. Observe the precautions printed on the bleach container. Rinse thoroughly.
- 7) Lubricate O-ring with a food grade silicone or

glycerin. Place O-ring back into groove in sump and smooth into place with your fingers. This step is important to ensure a proper watertight seal.

- 8) Insert a new cartridge over the standpipe in bottom of the sump. Refer to the diagram below.
- 9) Replace the sump by turning counter-clockwise and hand tighten. Do not over tighten.
- 10) Reconnect the main power supply.
- 11) Turn on the feed water supply using the manual inlet shut-off valve and allow the System to fill with water.
- 12) Push the "Power" button located on the RO Microprocessor Controller to restart the System.
- 13) Check for leaks.
- 14) Flush the System for a minimum of 5 minutes while diverting the product water to the drain.

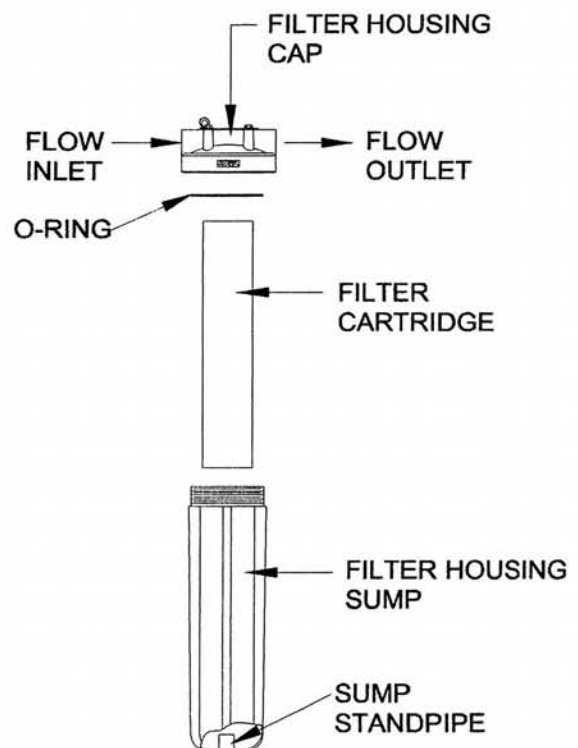

NOTE! The manufacturer of the filter housing recommends that the sump of all plastic housings be replaced every five years for a clear sump and every ten years for an opaque sump. Date the bottom of any new or replacement sump to indicate the next recommended replacement date.

IMPORTANT! Use sterile procedures when removing or replacing filters and membrane elements, or when working with the tubing containing product water.

SYSTEM PRESSURE SWITCHES

For BLS & WMS Models

INLET LOW PRESSURE SWITCH

Preset to shut down system if inlet pressure is below 15 psi.

An Inlet Low Pressure Switch is installed on every Reo-Pure System. The purpose of this switch is to prevent damage to the pump and/or motor if there is inadequate feed water flow or pressure.

How To Verify The Inlet Low Pressure Switch Is Functioning Properly...

To verify the setting, slowly decrease the inlet feed water supply by slowly closing the manual inlet shut-off valve while watching the pre-filter outlet pressure gauge. If the system shuts down when the pressure drops to approximately 15 PSI, then the Inlet Low Pressure Switch is functioning correctly.

CAUTION! Disconnect the power any time the cover is removed from a pressure switch.

How To Adjust The Inlet Low Pressure Switch Set Point...

If it is not set correctly, disconnect the power from the System and remove the black plastic cover of the pressure switch labeled "Inlet Low Pressure Switch". There are two screws for adjusting the switch settings. **Do not adjust the plastic screw.** Turn the brass screw clockwise to increase both the cut-in and cut-out pressure. Turn it counter clockwise to decrease both the cut-in and cut-out pressure. Turn the screw one half turn only. Temporarily replace the cover, reconnect the power and recheck the setting. Repeat as required.

How To Tell If You Have A Bad Low Pressure Switch...

Simply, close the inlet feed water valve, and if the System does not shut down, the pressure switch needs replacing.

PRODUCT WATER PRESSURE SWITCH

Preset to cut-out at 45 psi and cut-in at 25 psi.

A Product Water Pressure Switch is a standard feature on Reo-Pure LP-ES and LP-WMS R.O. Systems. Its purpose is to stop and start the R.O. system when a pressurized storage tank is used.

How To Verify The Product Water Pressure Switch Set Point...

You will need a ball valve and pressure gauge (0-100 psi) assembly with a tube connection the size of the R.O. system product tubing. You will also need a container to catch the product water.

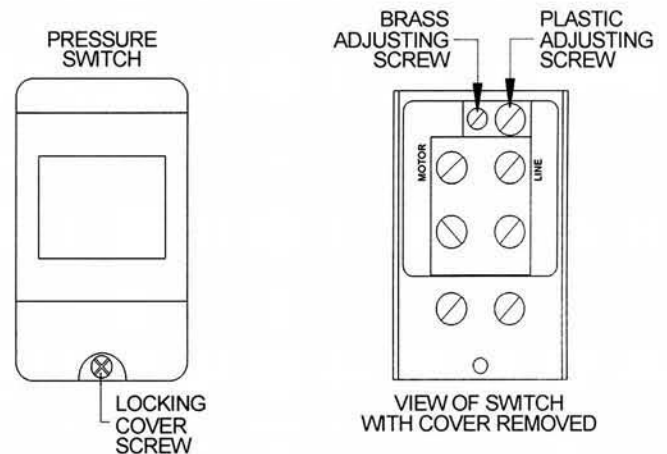

Disconnect the power from the System. Close the pressurized storage tank shut-off valve. Open a valve down stream of the pressurized storage tank to relieve the pressure from the system. Disconnect the tubing from the tank shut-off valve. Connect the ball valve/pressure gauge assembly to this tubing. Open the ball valve and put it into the container. Close the down stream valve. Reconnect the power to the R.O. system. Slowly close the new ball valve. If the R.O. system shuts down when the pressure gauge reaches approximately 45 PSI, the Product Water Pressure Switch is functioning correctly.

How To Adjust The Product Water Pressure Switch...

If it is not set correctly, disconnect the power to the R.O. system and remove the black plastic cover of the pressure switch labeled "Product Water Pressure Switch". There are two screws for adjusting the switch settings. **Do not adjust the plastic screw.** Turn the brass screw clockwise to increase both the cut-in and cut-out pressure. Turn it counter clockwise to decrease both the cut-in and cut-out pressure. Turn the screw one half turn only. Temporarily replace the cover, reconnect the power and recheck the setting. Repeat as required. When the Product Water Pressure Switch is set, reinstall the cover and tighten the locking screw. Disconnect the power, remove the ball valve or ball valve/pressure gauge assembly, reconnect the System and open the tank shut-off valve.

How To Tell If You Have A Bad Product Water Pressure Switch...

The System does not shut down when the pressurized storage tank is full, the Product Water Pressure Switch needs replacing. You should also notice water leaking/spraying from the pressure relief valve.

SERVICING THE MEMBRANE ELEMENT(S)

For Reo-Pure with Stainless Steel Membrane Vessel(s)

NOTE! *Determining how long membrane elements will last is nearly impossible. Normally, replacement is necessary whenever the product water production decreases by 20% at the same operating pressure, or when the TDS exceeds acceptable level.*

MEMBRANE ELEMENT REPLACEMENT

1. Close the manual feed water shut-off valve.
2. The Reo-Pure System will shut down after 5 seconds and the PRESSURE FAULT alarm will light/sound.
3. Disconnect the main power supply.

IMPORTANT! *Before performing any maintenance on your Reo-Pure System, always disconnect the power supply!*

4. Remove the upper split retaining ring from the pressure vessel.
5. Carefully remove the top end cap from the membrane pressure vessel.
6. The membrane element may come with the end cap. If so, carefully remove it.
7. Remove the membrane element from the vessel by pulling on the product water tube. Normally this can be done by hand. If additional leverage is required, use a pliers.

NOTE! *Observe the arrow on the vessel(s) which shows the direction of flow through the membrane vessel(s). If the arrow on the vessel points up, the brine seal on the membrane element should be on the bottom of the vessel. If the arrow on the vessel points down, the brine seal on the membrane element should be at the top of the vessel.*

8. Check internal and external o-rings on the end caps. If they are worn or damaged, they will need to be replaced.
9. Install the new membrane element in exactly the same manner as it was removed.

NOTE! *The brine seal end must always face the high pressure inlet to the vessel.*

10. Insert the top end cap. Be careful to keep the rubber o-rings in their grooves while inserting the end cap. Use food grade silicone or glycerin to lubricate the o-rings. Do not use a petroleum based product such as Vaseline.
11. Replace the upper split retaining ring.

IMPORTANT! *It is important to divert the product water to drain for approximately 30 to 60 minutes after changing a membrane element. This is done because membrane elements are treated with a preservative solution and should be thoroughly rinsed clean of any remnant. This can be done either by installing a 3-way valve in the product water line, or by disconnecting the pipe or hose/tube from your storage tank.*

CAUTION! *Be sure your product water line is disconnected from your storage tank before restarting the system. Divert product water to drain for 30 to 60 minutes.*

12. Reconnect the main power supply.
13. Turn on the feed water supply and allow the system to fill with water.
14. Turn on the "Power" button located on the RO Controller to restart the system.
15. Check for leaks.
16. Open the flush valve and flush the system for 2 to 3 minutes.
17. Close the flush valve and divert the product water to drain for 30 to 60 minutes.
18. After diverting to drain for 30 to 60 minutes, you may

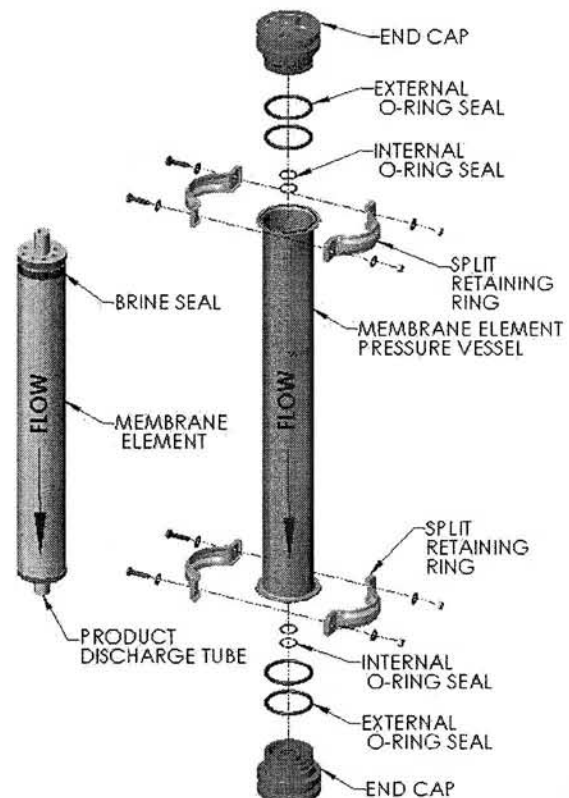

SANITIZING THE R.O. SYSTEM

The following procedure is recommended for preventive maintenance along with filter replacement. It is not intended to be effective in sanitizing highly contaminated systems which have been exposed to excessive amounts of bacteria, or systems which have foul-smelling membrane elements or filters. Such systems require extensive cleaning and sanitizing. Consult your REO-PURE dealer for further information.

- 1) Close the manual feed water shut-off valve.
- 2) The System will shut down after 5 seconds and the PRESSURE FAULT alarm will light/sound.
- 3) Relieve all the pressure from the System by opening the reject water valve.
- 4) Disconnect the main power supply.

IMPORTANT! Before performing any maintenance on your Reo-Pure System, always disconnect the main power supply!

- 5) Remove the filter sump by turning clockwise.
- 6) Remove and discard the used filter cartridge.
- 7) Rinse out the bottom of the sump and fill about 1/3 full of water. Add about two tablespoons of household bleach and scrub the cap and housing with a non-abrasive sponge or cloth. Observe the precautions printed on the bleach container. Rinse out filter sump.
- 8) Pour about two (2) tablespoons of bleach into the filter sump. Reinstall the filter sump without the filter cartridge, making sure the O-ring is seated properly.

NOTE! It is important that the O-ring be properly seated each time the filter housing is reassembled or removed.

- 9) Empty the product water storage tank.
- 10) Temporarily disconnect the product water connection from the storage tank and run the line to a drain.

- 11) Reconnect the power supply.
- 12) Turn on the feed water supply and run the System until the sanitizing solution can be detected (by smell) in the product water flow.
- 13) Turn off the System and let it sit for 8 hours.
- 14) Disconnect the main power supply to the System.
- 15) After 8 hours, remove the filter sump as before. Empty it of any chlorinated water.
- 16) Remove the O-ring and wipe it clean. Lubricate it with a food grade silicone or glycerin. Place the O-ring back into the groove in the sump and smooth it into place with your fingers. This step is important to ensure a proper watertight seal.
- 17) Insert a new filter cartridge over the standpipe in the bottom of the filter sump.
- 18) Replace the sump by turning counter-clockwise and hand tighten. Do not over tighten.
- 19) Turn on the main power supply to the System, and turn on the feed water supply using the manual inlet shut-off valve and allow the System to fill with water.
- 20) Push the POWER button on to start the System.
- 21) Check for leaks.
- 22) Thoroughly flush the System of any residual chlorine by running the water to drain for 10 to 15 minutes.
- 23) Turn off the System and reconnect the product water line to the storage tank and return the System back to its normal operation.

NOTE! The ONLY time the membrane element should come into contact with chlorine is during this procedure.

If the product water storage tank is heavily contaminated, it will need to be sanitized separately.

BLS & WMS SYSTEM REPLACEMENT PARTS LIST

REO-PURE 3000 / 6000 / 9000 OPTIMUM STANDARD AND ECONO MODELS

PART NO.	DESCRIPTION	SYSTEMS	QTY 3000/6000/9000
MEMBRANE ELEMENTS			
7030404002	Membrane Element, XLE-4040	3000/6000/9000	1 / 2 / 3
MEMBRANE PRESSURE VESSELS			
100040402	Membrane Pressure Vessel Assy., Stainless Steel, 4" x 40"	3000/6000/9000	1 / 2 / 3
100041212	2-Port End Plug for 4" S.S. Vessel	3000/6000/9000	2 / 4 / 6
1300342	O-Ring, External, for 4" Cap	3000/6000/9000	2 / 4 / 6
1300210	O-Ring, Internal, for 4" Cap	3000/6000/9000	2 / 4 / 6
100041215	Clamp Assembly for 4" S.S. Vessel	3000/6000/9000	2 / 4 / 6
FILTER HOUSING & CARTRIDGES			
150467-2	#20 BB Filter Housing 3/4"		1
14815564	20" Sediment Cartridge 5-Micron BB		1
PUMPS & MOTORS			
3060712	HP Booster Pump HP7D, 3/4HP, 230V, 60Hz, 1Ph	3000 60Hz	1
3060720	HP Booster Pump HP10E, 1HP, 230V, 60Hz, 1Ph	6000 60Hz	1
3060722	HP Booster Pump HP10F-02, 1-1/2HP, 230V, 60Hz, 1Ph	9000 60Hz	1
3060713	Pump HP Booster 5HP10F, 1-1/2HP, 230V, 50Hz, 1Ph	3000 50Hz	1
3060721	Pump HP Booster 5HP10G, 2HP, 230V, 50Hz, 1Ph	6000/9000 50Hz	1
SOLENOID VALVES			
00934220E	Inlet Solenoid Valve w/Coil, Brass, 3/4" NPTF, 220/230V	3000/6000/9000	1
00938220E	Auto Flush Solenoid Valve w/Coil, Brass, 3/8" NPTF, 220/230V (Optimum)	3000/6000/9000	1
MISCELLANEOUS			
4819012	RO Controller S-150, 0-100 PPM, 230V, 60Hz, 1Ph	3000/6000	1
4819018	RO Controller S-150, 0-100 PPM, 230V, 60/Hz, 1Ph	9000	1
4819018	RO Controller S-150, 0-100 PPM, 230V, 50 Hz, 1Ph (Optional Hz)	3000/6000/9000	1
4819021	RI Controller s-100, 0-999 ppm, 230V, 50/60Hz, 1PH (ECONO)	3000/6000	1
4819022	RI Controller s-100, 0-999 ppm, 230V, 50/60Hz, 1PH (ECONO)	9000	1
4819022	RI Controller s-100, 0-999 ppm, 230V, 50Hz, 1PH (ECONO)	3000/6000/9000	1
48450500	Product Water Flow Meter 0.5-5.0 GPM	3000/6000	1 / 1 / 0
48450500	Reject Water Flow Meter 0.5-5.0 GPM	3000/6000/9000	1 / 1 / 0
48450750	Product Water Flow Meter 1-10 GPM	9000	0 / 0 / 1
312503	Reject Valve, 1/2" NPTM ,S/S	3000/6000/9000	1
17506902	Inlet Feed Water Low Pressure Switch	3000/6000/9000	1
17506905	Product Water Pressure Switch (Optional)	3000/6000/9000	1
0700708	Product Pressure Relief Valve (Optional)	3000/6000/9000	1
1720138	System Pressure Regulator	3000/6000/9000	1
31403844	Manual Flush Valve, 3/8" NPTF X 3/8" NPTF, Brass (Standard)	3000/6000/9000	1
008001	Pre-Filter Inlet Pressure Gauge 0-100 PSI (Dry)	3000/6000/9000	1
008001	Pre-filter Outlet Pressure Gauge 0-100 PSI (Dry)	3000/6000/9000	1
008013	System Operating Pressure Gauge 0-300 PSI	3000/6000/9000	1
316050	Product Water Check Valve 1/2"	3000/6000	1 / 1 / 0
316051	Product Water Check Valve 3/4"	9000	0 / 0 / 1
0002621007	Inlet Feed Water Manual Shut-Off Valve, 3/4" NPTF, PVC (Optional)	3000/6000/9000	1
31400051	3-Way Ball Valve 1/2" NPTF For Reject Cleaning Ports (Optional)	3000/6000/9000	1
31400075	3-Way Ball Valve 3/4" NPTF For Product Cleaning Ports (Optional)	3000/6000/9000	1

REO-PURE SYSTEM

LIMITED WARRANTY

Great Lakes International, Inc. warrants that each REO-PURE system is free of defects in material and workmanship and has been factory tested to perform in accordance with published specifications at the time of shipment. Great Lakes International, Inc. further warrants that the REO-PURE system will continue to operate for a period of one (1) year from start-up, or 15 months from purchase, whichever is shorter, provided that the user supplies feed water meeting minimum standards stated in the REO-PURE Operating Manual and adopts and implements the maintenance program recommended in the REO-PURE Operating Manual.

Parts which are sold but not manufactured by Great Lakes International, Inc. are subject to the warranty of the manufacturer. Expendable or consumable products, filter cartridges, chemicals, etc., which by nature have a shorter life expectancy than twelve months, are not covered under this warranty.

The Great Lakes International, Inc.'s liability under this warranty is limited to the repair or replacement at Great Lakes International, Inc.'s discretion of systems or components, F.O.B. Great Lakes International, Inc.'s factory, found defective solely as to materials or workmanship during the warranty term. Great Lakes International, Inc. will not be liable for any cost for removal, installation, transportation, or any other charges which may arise in connection with a warranty claim. This warranty does not extend to any system or components which failed due to; 1) Damage from mishandling, misuse, abuse, abnormal operating conditions, improper maintenance procedures, accident, unauthorized modification, or neglect, 2) Improper installation or, 3) Incorrect electrical supply. This warranty is void if serial numbers are mutilated or missing.

Great Lakes International, Inc.'s membrane elements are guaranteed to operate within specifications when used for general water treatment for a period of 12 months from date of purchase providing that the membrane element has not been misapplied or used with feed water that does not meet the minimum standards stated in the REO-PURE Operating Manual.

A membrane element, which fails to perform satisfactorily within the first 30 days after receipt, has not been mishandled or misapplied, and is returned prepaid to Great Lakes International, Inc.'s factory, will be replaced free of charge except for freight and local labor. If a membrane element fails to perform satisfactorily during the balance of the warranty period, and is returned prepaid, Great Lakes International, Inc. will replace the membrane element with a new membrane element and will charge the returner for the portion of the 12 months that the membrane element was used plus the return freight. The pro rata charges will be based on the price prevailing at the time of warranty consideration. Membrane elements must be kept damp at all times and must be clean and bagged in a watertight bag before returning.

To obtain warranty consideration, the defective product must be returned to Great Lakes International, Inc. prepaid together with proof of purchase, installation date, failure date and supporting technical data. All documentation supporting the warranty claim and a Returned Goods Authorization (RGA) number must be included.

GREAT LAKES INTERNATIONAL, INC.'S OBLIGATION UNDER THIS WARRANTY IS LIMITED TO REPAIR OR REPLACEMENT OF THE DEFECTIVE PART. GREAT LAKES INTERNATIONAL, INC. ASSUMES NO LIABILITY WHATSOEVER FOR INCIDENTAL OR CONSEQUENTIAL DAMAGES, LOSSES OR EXPENSES ARISING FROM INSTALLATION, USE OR ANY OTHER CAUSES. THERE ARE NO EXPRESSED OR IMPLIED WARRANTIES BEYOND THOSE WARRANTIES DESCRIBED OR REFERRED TO ABOVE.

Great Lakes International Inc.
Racine, Wisconsin, U.S.A.

REO-PURE R.O. SYSTEM TROUBLESHOOTING

PROBLEM	POSSIBLE CAUSE	SOLUTION
REO-PURE SYSTEM WILL NOT START	No electrical power to microprocessor Storage tank full Low feed water pressure Pump / motor malfunction Pressure or float switch defective	Check power supply Drain portion of water out of tank See LOW FEED PRESSURE Check, replace if necessary Check, replace if necessary
LOW FEED PRESSURE	Manual feed water valve not open Inlet solenoid valve not open Low inlet water pressure Filters plugged Obstructed feed line Inadequate upstream pretreatment	Open valve Check, replace if necessary Check, increase pressure Check, replace if necessary Check inlet piping Check if sized correctly or fouled
LOW OPERATING PRESSURE	System pressure regulator needs adjustment Pump / motor coupling broken Pressure gauge broken Pump impellers worn Low water volume to pump Malfunctioning pump Membrane element brine seal is folded or not sealed against housing wall Inlet solenoid valve not opening Membrane element fouled Autoflush On	Check, adjust if necessary Check, replace if necessary Check, replace if necessary Check, replace if necessary See LOW FEED PRESSURE Check, replace if necessary Check valve seal, use care when reinstalling the element into vessel Clean solenoid valve or replace Check, clean or replace Check controller, Check Autoflush program
LOW OR NO REJECT WATER / HIGH OPERATING PRESSURE	Blocked drain line Reject valve blocked or damaged Flow meter inaccurate Membrane element clogged or fouled	Check and clean Remove reject valve stem. Check for damage or blockage. Clean or replace. Check reject flow manually with stop watch. Repair or replace flow meter. Check, clean or replace
LOW OR NO PRODUCT WATER	Pump pressure low Membrane element clogged or fouled Water temperature too low Product check valve damaged Membrane element installed backward or brine seal damaged / rolled Flow meter incorrect	Check and adjust Check, clean or replace Check Replace check valve Check, use care when replacing element into housing Check product flow manually with a stop watch. Repair or replace flow meter.
BAD TASTING WATER	Increase in feed water TDS Filter cartridges exhausted Tank and system contaminated Tank contaminated Membrane element not flushed completely	See HIGH TDS IN PRODUCT WATER Replace filter cartridges Replace filter cartridges and membrane element, sterilize system and tank Re-sterilize tank Flush one or two tanks of product water
PUMP DOES NOT RUN	Defective controls Pump is bound Pump / motor coupling damaged	Check controller and wiring Manually check pump rotation, replace if necessary Check, replace if necessary
HIGH TDS IN PRODUCT WATER	Membrane element expended Insufficient reject flow rate Increase in feed water TDS Product tube o-ring camaged or out of place Conductivity monitor inaccurate or probe fouled	Check, replace if necessary Check, reject flow must be at least equal to product flow Use percent rejection to calculate increase in product TDS Remove top and bottom end caps from housing. Reinstall or replace o-ring. Calibrate monitor. Check monitor connections. Clean or replace probe.
CLOUDY WATER	Dissolved air in feed water concentrated in product water	Usually clears up as condition of feed water changes. Letting water stand will allow dissolved air to dissipate.

COMPONENT LIST

1. PRE-FILTER INLET PRESSURE GAUGE
2. PRE-FILTER OUTLET PRESSURE GAUGE
3. FILTER HOUSING & SEDIMENT CARTRIDGE
4. LOW PRESSURE CUT-OFF SWITCH
5. INLET WATER SOLENOID VALVE
6. HIGH PRESSURE PUMP AND MOTOR
7. R. O. MEMBRANE
8. R. O. MODULE (MEMBRANE HOUSING)
9. RECIRCULATION VALVE
10. PUMP PRESSURE GAUGE
11. REJECT VALVE
12. REJECT WATER FLOW METER
13. MANUAL FLUSH VALVE
14. PRODUCT WATER CHECK VALVE
15. MANUAL INLET SHUT-OFF BALL VALVE (OPTION)
16. PRODUCT WATER FLOW METER
17. PRODUCT WATER PRESSURE GAUGE (OPTION)
18. PRODUCT WATER PRESSURE SWITCH (OPTION)

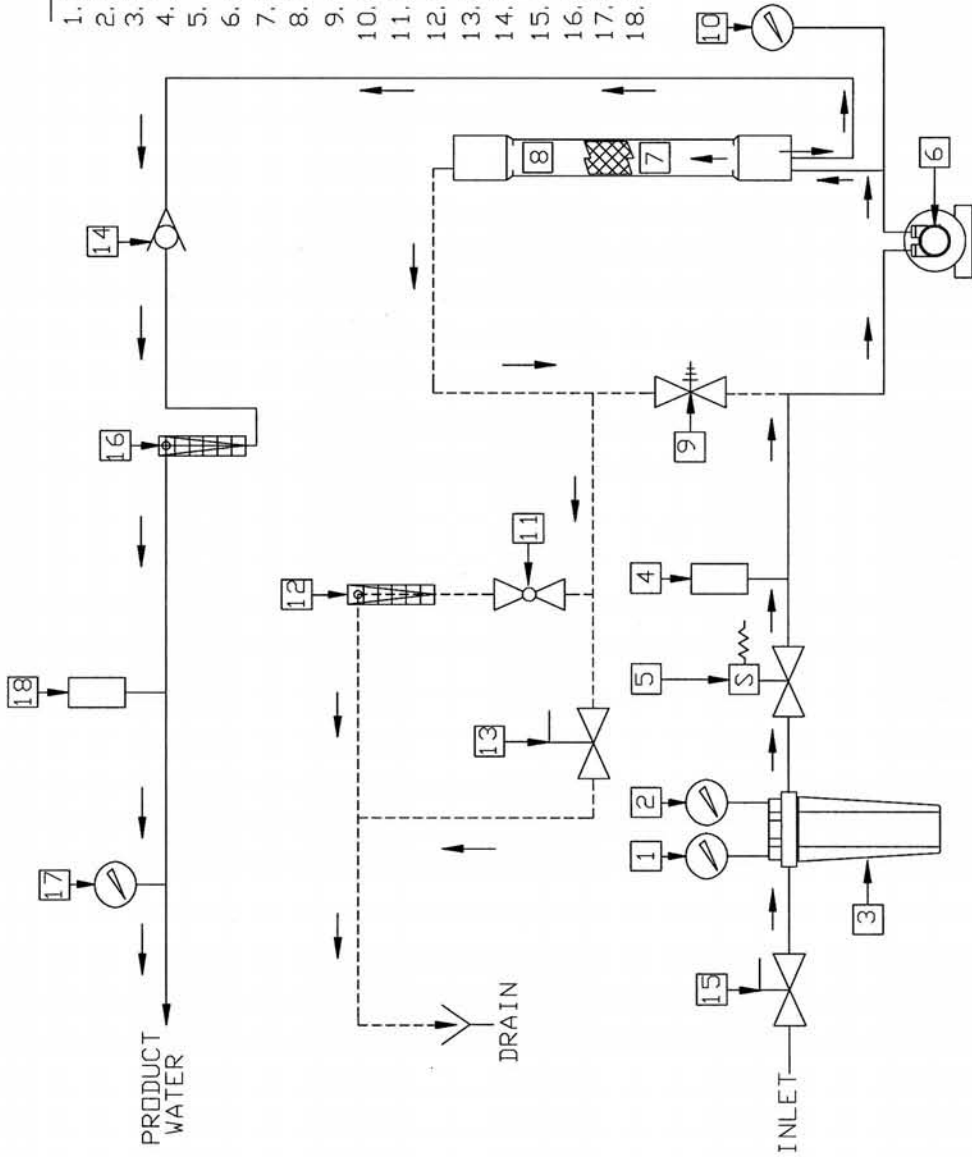

NOTE:
 --- REJECT/RECIRCULATING WATER
 ——— DEPICTS WATER FLOW

REVISIONS:		GREAT LAKES INTERNATIONAL INC. 1800 KEARNEY AVENUE MADISON WISCONSIN 53704 U.S.A. WMS & BLS 400 950 2400 STANDARD FLOW DIAGRAM
NO.	DATE:	
UNLESS OTHERWISE SPECIFIED DIMENSIONS ARE IN INCHES ALL DIMENSIONS TO FACE UNLESS NOTED OTHERWISE TOLERANCES: 1" > 1/2" ± 0.015 1/2" & SMALLER ± 0.005		
PROHIBITARY AND CONFIDENTIAL THE INFORMATION CONTAINED IN THIS DRAWING IS THE SOLE PROPERTY OF GREAT LAKES INTERNATIONAL INC. ANY REPRODUCTION OR PARTIAL REPRODUCTION WITHOUT THE WRITTEN PERMISSION OF GREAT LAKES INTERNATIONAL INC. IS PROHIBITED.		DATE: 4/25/2008 DRAWN BY: R.J.I. DWG. NO. BLS400STD SHEET 1 OF 1

WIRING DIAGRAM APPLIES ONLY TO REO PURE COMPONENTS

- NOTES: 1) DASHED LINES INDICATE FIELD WIRING BY CUSTOMER
 2) FOR 240V OPERATION A SINGLE JUMPER MUST BE BETWEEN P3 AND P4.
 3) FUSES MUST BE INSTALLED AT F1 & F2
 4) ALL SWITCH INPUTS MUST BE DRY CONTACTS ONLY! IF VOLTAGE IS APPLIED TO THESE INPUTS, DAMAGE TO THE CONTROLLER WILL RESULT.
 5) FOR POWER WITH NEUTRAL AND HOT LEADS, L1 IS HOT AND L2 IS NEUTRAL
 6) CAUTION! THIS SYSTEM MUST BE INSTALLED WITH DISCONNECTING MEANS AS PER ELECTRICAL CODE.

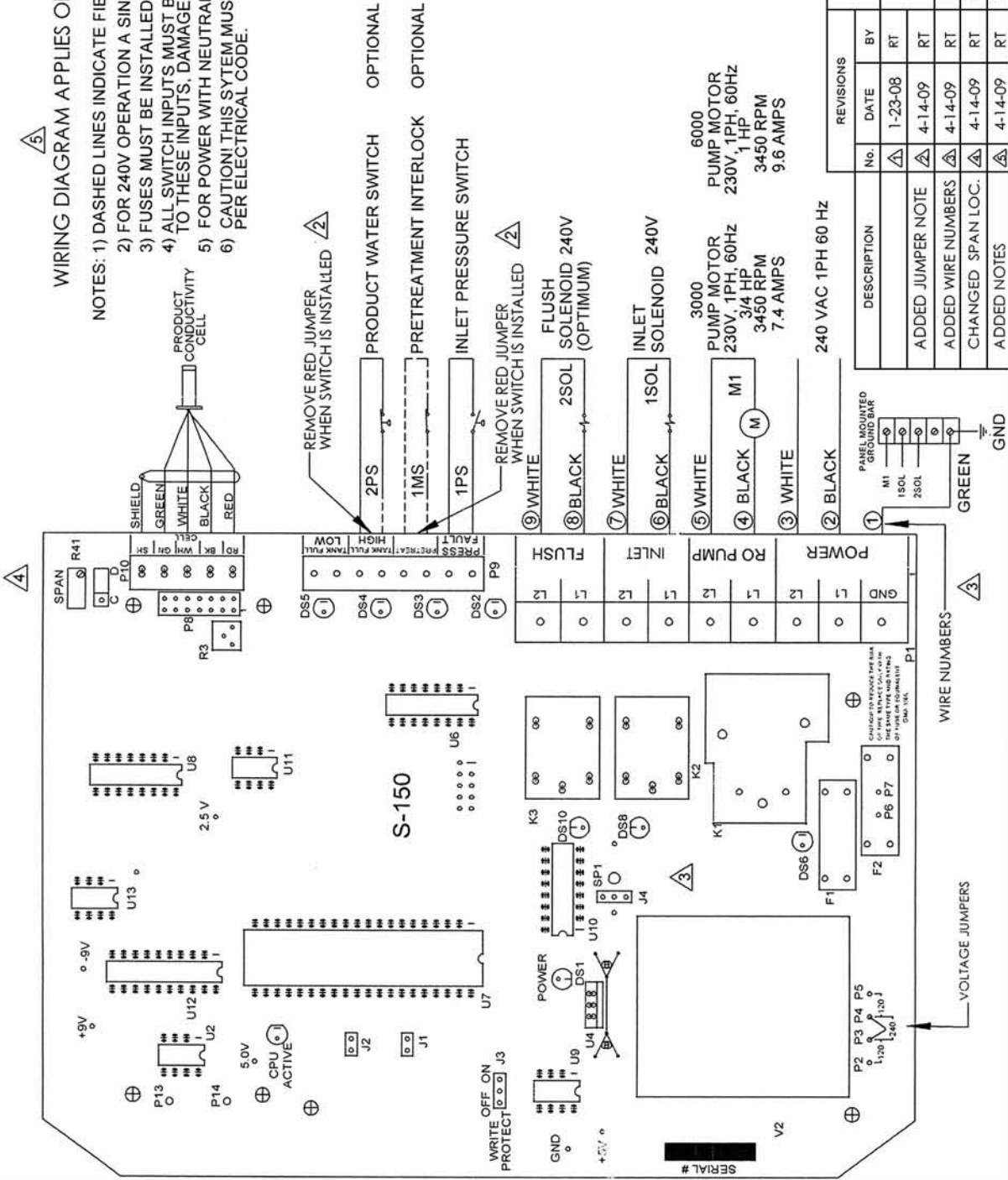

ELECTRICAL SCHEMATIC WITH PRESSURIZED STORAGE

GREAT LAKES INTERNATIONAL INC.
 1905 KEARNEY AVENUE RACINE WISCONSIN 53403 U.S.A.

3000/6000 WIRING DIAGRAM
240V/60Hz/1PH S-150 CONTROL

DRAWN BY: MAM SCALE: N/A MATERIAL: _____
 CHK'D: _____ DATE: 1-9-07 DRAWING No. 3000S1501PH60HZP240
 TRACED: _____ APP'D: _____

WIRING DIAGRAM APPLIES ONLY TO REO PURE COMPONENTS

- NOTES: 1) DASHED LINES INDICATE FIELD WIRING BY CUSTOMER
 2) FOR 240V OPERATION A SINGLE JUMPER MUST BE BETWEEN P3 AND P4.
 3) FUSES MUST BE INSTALLED AT F1 & F2
 4) ALL SWITCH INPUTS MUST BE DRY CONTACTS ONLY! IF VOLTAGE IS APPLIED TO THESE INPUTS, DAMAGE TO THE CONTROLLER WILL RESULT.
 5) FOR POWER WITH NEUTRAL AND HOT LEADS, L1 IS HOT AND L2 IS NEUTRAL
 6) CAUTION! THIS SYSTEM MUST BE INSTALLED WITH DISCONNECTING MEANS AS PER ELECTRICAL CODE.

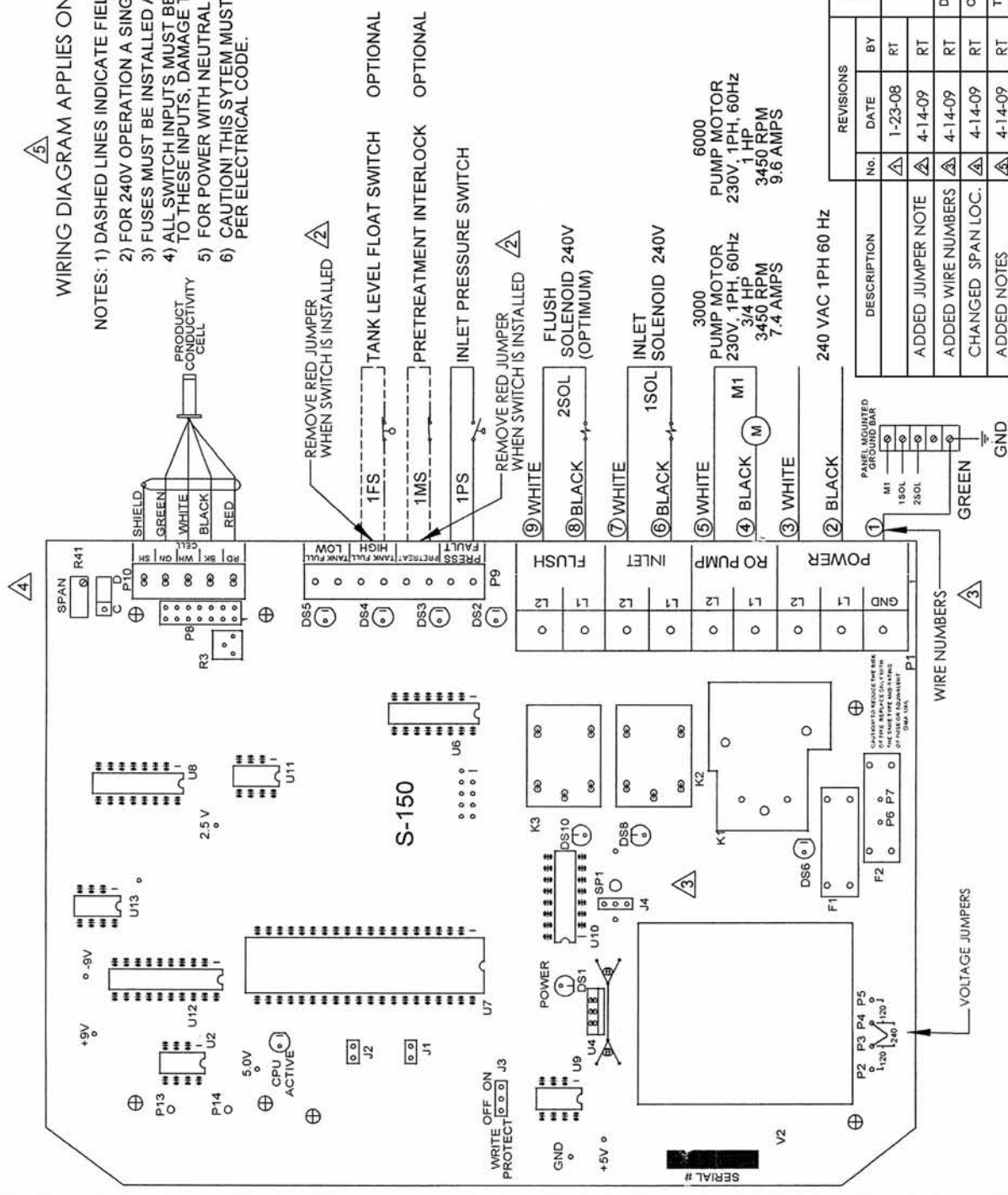

ELECTRICAL SCHEMATIC WITH ATMOSPHERIC STORAGE

GREAT LAKES INTERNATIONAL INC. 1905 KEARNEY AVENUE RACINE WISCONSIN 53403 U.S.A.		
3000/6000 WIRING DIAGRAM		
240V/60Hz/1PH S-150 CONTROL		
DRAWN BY: MAM	SCALE: N/A	MATERIAL
CHKD: []	DATE: 1-9-07	DRAWING No. 3000S1501PH60HA240
TRACED	APPD	

No.	DESCRIPTION	REVISIONS	
		DATE	BY
1	ADDED JUMPER NOTE	1-23-08	RT
2	ADDED WIRE NUMBERS	4-14-09	RT
3	CHANGED SPAN LOC.	4-14-09	RT
4	ADDED NOTES	4-14-09	RT